

FEATURES

- 65536 True Colors
- LCD Lifetime up to 50,000 Hours
- 800x480 Pixels
- 7" LCD Display Screen
- HMI and PLC are attached
- IP65 Protection Level on Front Panel
- 24 VDC Input Voltage
- Backlight LED
- 128M Flash and 32M DDR Memory
- Communication Ports: USB2.0, RS485



DESCRIPTION

The HP070-33DT is an HMI with integrated PLC that provides a reliable system to help your application run smoothly and efficiently. This HMI/PLC combination unit comes with a 65536 color display mode that enhances your touch screen with rich color and incomparable resolution. The IP65-rated front screen is protected against dust ingress, and it may be subjected to low-pressure water jets. On the backside, the PLC is directly attached and integrated into the same package with the HMI. The PLC provides special I/O functions, a USB2.0 (USB-B Connector) programming port, two high-speed counters, two high-speed outputs, two RS485 communication/serial ports, 16 discrete inputs, 14 output channels, two analog input channels, and one analog output channel. The built-in high-speed pulse outputs can reach a maximum frequency of 50 KHz. The KincoBuilder software provides absolute and relative positioning, homing, jogging, and quick stop instructions for programming the PLC functions of this device. The HP Builder software is a convenient and powerful configuration software for the HMI/screen programming that facilitates the creation of first-class, efficient programs. KincoBuilder and HP Builder software are both required to operate this integrated device, and are available for free on our website. The integration of the HMI and PLC make the HP070-33DT the perfect choice for a quick, easy set-up and its combination of the HMI and PLC makes it a smart choice for our customers.

DIMENSIONS

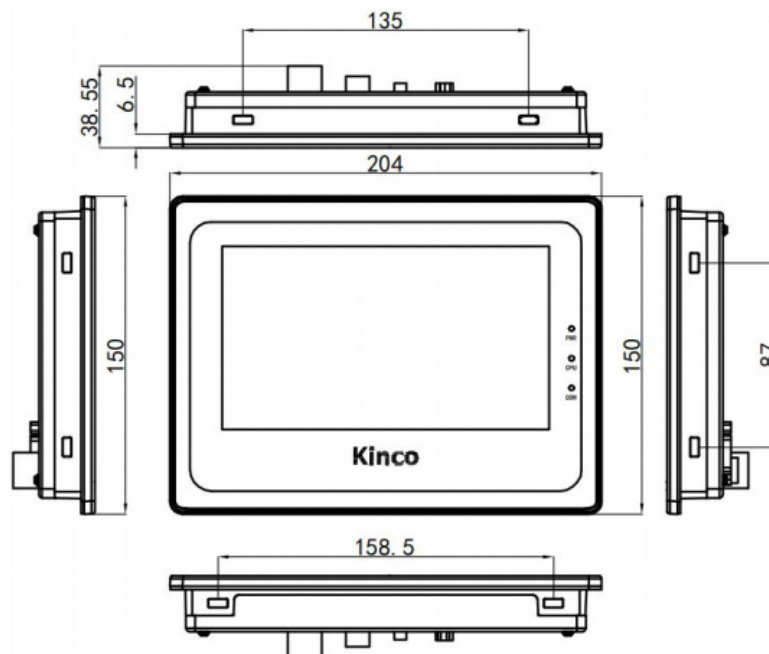

L011918

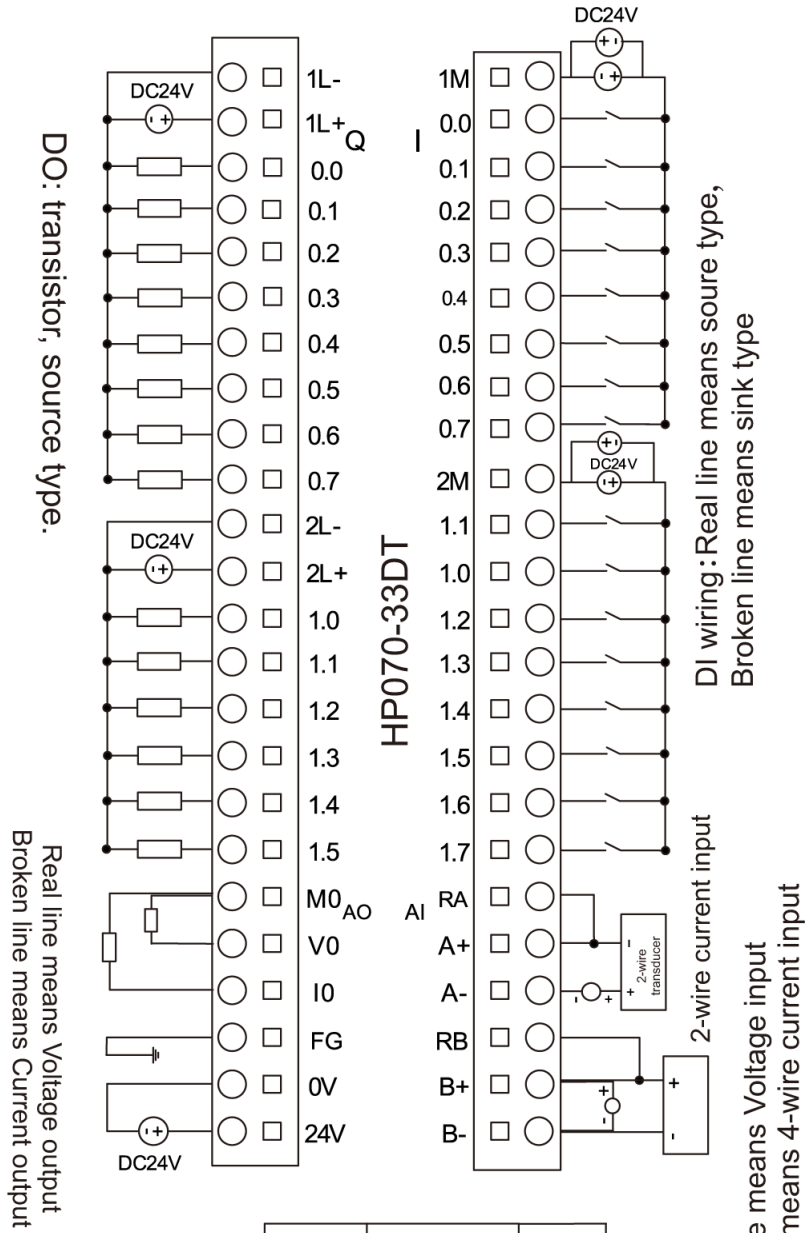

RS485(IN DB9)

	Function	Pin
Port1	A	6
	B	1
Port2	A	9
	B	4
XII	GND	5

Performance Specification	
Display	7" TFT (16:9)
Resolution	800x480 Pixels
Color	65,536 Colors
Backlight	LED
Brightness	300 cd/m ²
Backlight Life	50,000 Hrs
Touch Panel	4-Wire, Resistor Web, 4H
Processor	32-bit RISC CPU 520 MHz
Memory	128M Flash + 32M DDR
Expandable Memory	1 USB Host
Recipe Memory & RTC	256 KB + RTC
Program Download	1 USB 2.0 Port
Serial / COM Port	2*RS485; Port 1 & Port 2, Baudrate up to 115.2KBPS Port 1: Support Programming, ModBus RTU and Slave, Free Communication Port 2: Modbus RTU Slave, Free Communication
Built-in Digital Points	16*DI / 14*DO
Built-in Analog Points	2*AI, 1*AO
Expansion Modules	Up to 8 Module; Support KS Series Expansion Module
Electrical Specification	
Rated Power	2.4W
Rated Voltage	24 VDC
Input Range	12~28 VDC
Voltage Range	DC 20.4V - 28.8V
Insulation Resistance	> 50M Ω @ 500 VDC
Dielectric Strength Test	500 VAC 1 Minute
Structure Specification	
Shell Color	Black and Grey
Shell Material	ABS
Dimensions(mm)	204 x 150 x 38.55
Cutout Size(mm)	119 x 93
Weight (kg)	0.66
Environment Specification	
Operating Temperature	0°~ +50° C
Operating Humidity	10~90% Non-Condensing
Storage Temperature	-10°~ +60° C
Storage Humidity	10~90% Non-Condensing
Cooling Method	Natural Air Cooling
Certification	
Degree of Protection	IP65 (Front Panel)